

Tipo - Type VA75 - A101 - 90A Aspirante - Suction	Diametro ventola - Fan diameter 182 mm
-----------------------------------------------------------------	------------------------------------------------------

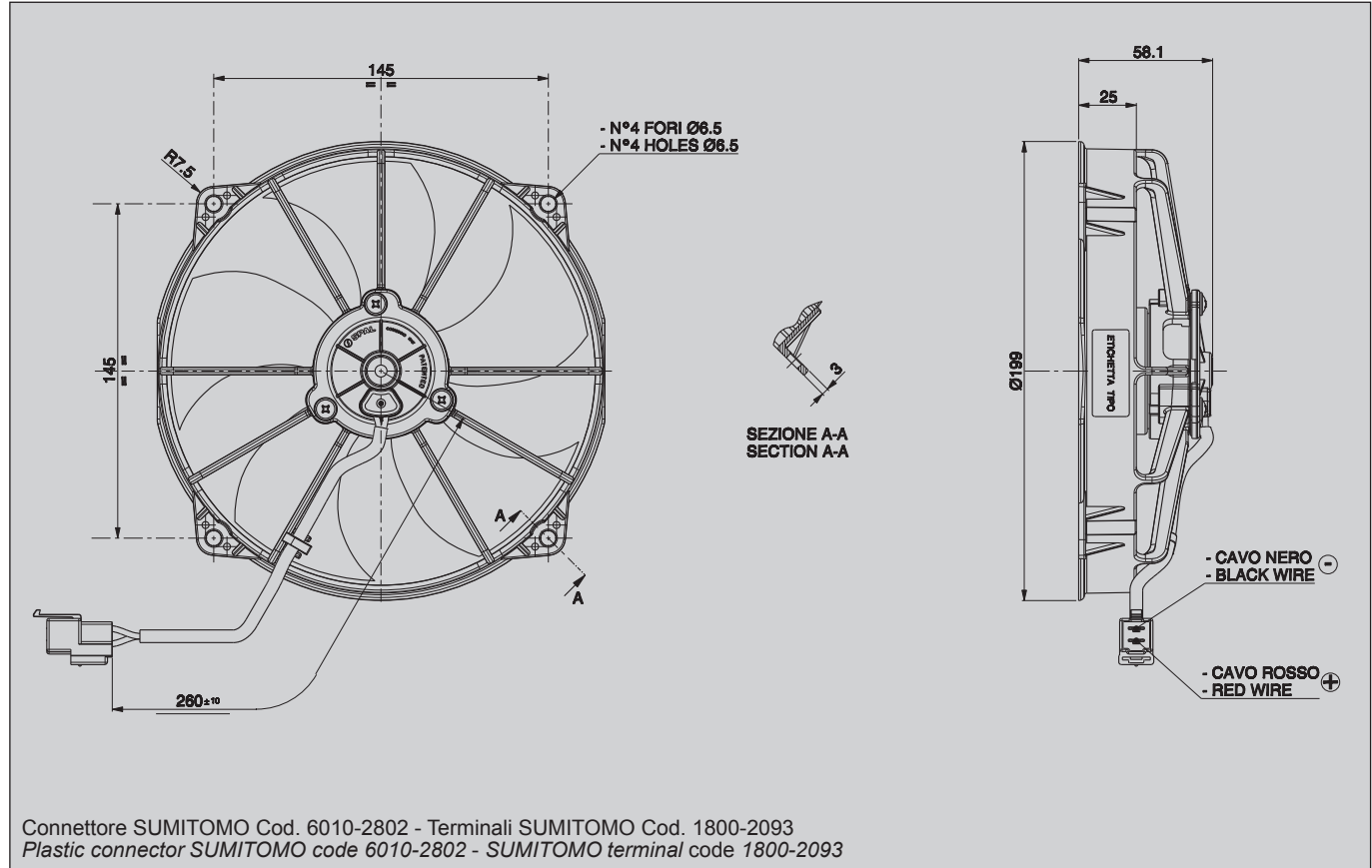

182



* Peso 0,456 kg. circa

* Weight 0,456 Kg. approx.

* Motore chiuso, IP 68

* Waterproof motor, IP 68

* Per motori IP68 consigliamo connettori a tenuta stagna, disponibili a richiesta

* For IP68 motor we suggest waterproof connector, available upon request

* Accessori disponibili: tutti i kit di fissaggio.

* Available accessories: all the fixing kits.

* Bassa rumorosità

* Low noise



Tensione di prova 13 V cc - Test voltage 13 V DC

Pressione statica Static pressure mm H ₂ O	Portata Airflow m ³ /h	Corrente assorbita Current input A
0	700	4,3
2,5	660	4,3
5	620	4,5
7,5	580	4,6
10	540	4,7
12,5	500	4,9
15	470	5,0
17,5	420	5,1
20	330	5,3
25	200	5,7
27,5	130	5,9
35	0	6,3

Static pressure: 1 mm H₂O = 0,04 in. H₂O
Airflow: 1 m³/h = 0,59 cfm