

Tipo - Type VA01-AP76/LL-89A Aspirante - Suction	Diametro ventola - Fan diameter 305 mm
--	--

305

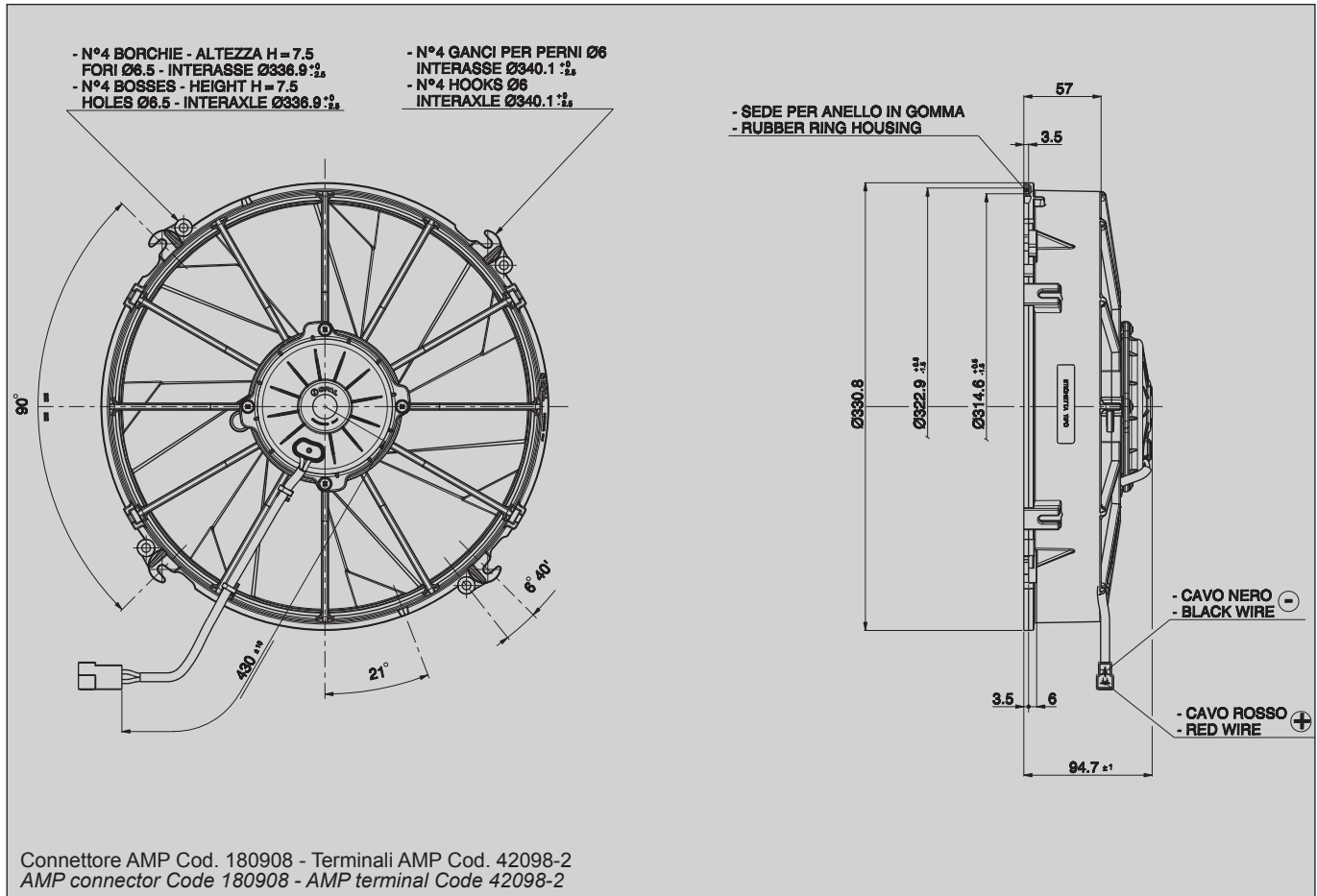

Tensione di prova 13 V cc - Test voltage 13 V DC

* Peso 2,500 kg. circa

* Weight 2,500 Kg. approx.

* Motore chiuso, IP 68

* Waterproof motor, IP 68

* Per motori IP68 consigliamo connettori a tenuta stagna, disponibili a richiesta

* For IP68 motor we suggest waterproof connector, available upon request

* Lunga durata

* Long life

* A richiesta (per applicazioni OEM) disponibile anche in versione VLL.

* Available also in VLL version for OEM applications only

* Accessori disponibili: tutti i kit di fissaggio

* Available accessories: all the fixing kits

* Bassa rumorosità

* Low noise

Pressione statica Static pressure mm H ₂ O	Portata Airflow m ³ /h	Corrente assorbita Current input A
0	2380	15,4
5	2210	16,9
10	2020	18,0
15	1820	19,2
20	1600	20,2
25	1300	21,2
30	950	22,2
35	690	23,4
40	390	24,0
50	0	26,2

Static pressure: 1 mm H₂O = 0,04 in. H₂O
 Airflow: 1 m³/h = 0,59 cfm